

## CHAPTER 3

### SITE EVALUATION PROCEDURES

#### 3.1 Introduction

The environment into which the wastewater is discharged can be a valuable part of an onsite wastewater and disposal system. If utilized properly, it can provide excellent treatment at little cost. However, if stressed beyond its assimilative capacity, the system will fail. Therefore, careful site evaluation is a vital part of onsite system design.

#### 3.2 Disposal Options

In general, facilities designed to discharge partially treated wastewater to the soil for ultimate disposal are the most reliable and least costly onsite systems. This is because little pretreatment of the wastewater is necessary before application to the soil. The soil has a very large capacity to transform and recycle most pollutants found in domestic wastewaters. While the assimilative capacity of some surface waters also may be great, the quality of the wastewater to be discharged into them is usually specified by local water quality regulatory agencies.

To achieve the specified quality may require a more costly treatment system. On the other hand, evaporation of wastewater into the atmosphere requires little wastewater pretreatment, but this method of disposal is severely limited by local climatic conditions. Therefore, the soil should be carefully evaluated prior to the investigation of other receiving environments.

##### 3.2.1 Wastewater Treatment and Disposal by Soil

Soil is the weathered and unconsolidated outer layer of the earth's surface. It is a complex arrangement of primary mineral and organic particles that differ in composition, size, shape, and arrangement. Pores or voids between the particles transmit and retain air and water. Since it is through these pores that the wastewater must pass to be absorbed and treated, their characteristics are important. These are

determined largely by the physical properties of the soil. Descriptions of some of the more important physical properties appear in Appendix A.

The soil is capable of treating organic materials, inorganic substances, and pathogens in wastewater by acting as a filter, exchanger, adsorber, and a surface on which many chemical and biochemical processes may occur. The combination of these processes acting on the wastewater as it passes through the soil produces a water of acceptable quality for discharge into the groundwater under the proper conditions.

Physical entrapment of particulate matter in the wastewater may be responsible for much of the treatment provided by soil. This process performs best when the soil is unsaturated. If saturated soil conditions prevail, the wastewater flows through the larger pores and receives minimal treatment. However, if the soil is kept unsaturated by restricting the wastewater flow into the soil, filtration is enhanced because the wastewater is forced to flow through the smaller pores of the soil.

Because most soil particles and organic matter are negatively charged, they attract and hold positively charged wastewater components and repel those of like charge. The total charge on the surfaces of the soil system is called the cation exchange capacity, and is a good measure of the soil's ability to retain wastewater components. The charged sites in the soil are able to sorb bacteria, viruses, ammonium, nitrogen, and phosphorus, the principal wastewater constituents of concern. The retention of bacteria and viruses allows time for their die-off or destruction by other processes, such as predation by other soil microorganisms (1)(2). Ammonium ions can be adsorbed onto clay particles. Where anaerobic conditions prevail, the ammonium ions may be retained on the particles. If oxygen is present, bacteria can quickly nitrify the ammonium to nitrate which is soluble and is easily leached to the groundwater. Phosphorus, on the other hand, is quickly chemisorbed onto mineral surfaces of the soil, and as the concentration of phosphorus increases with time, precipitates may form with the iron, aluminum, or calcium naturally present in most soils. Therefore, the movement of phosphorus through most soils is very slow (1)(2).

Numerous studies have shown that 2 ft to 4 ft (0.6 to 1.2 m) of unsaturated soil is sufficient to remove bacteria and viruses to acceptable levels and nearly all phosphorus (1)(2). The needed depth is determined by the permeability of the soil. Soils with rapid permeabilities may require greater unsaturated depths below the infiltrative surface than soils with slow permeabilities.

### 3.2.2 Wastewater Treatment and Disposal by Evaporation

Wastewater can be returned directly to the hydrologic cycle by evaporation. This has appeal in onsite wastewater disposal because it can be used in some areas where site conditions preclude soil absorption or in areas where surface water or groundwater contamination is a concern. The wastewater can be confined and the water removed to concentrate the pollutants within the system. Little or no treatment is required prior to evaporation. However, climatic conditions restrict the application of this method.

Evaporation can take place from a free water surface, bare soil, or plant canopies. Evaporation from plants is called transpiration. Since it is often difficult to separate these two processes on partially bare soil surfaces, they are considered as a single process called evapotranspiration (ET).

If evaporation is to occur continuously, three conditions must be met (3). First, there must be a continuous supply of heat to meet the latent heat requirements of water (approximately 590 cal/gm of water evaporated at 15° C). Second, the vapor pressure in the atmosphere over the evaporative surface must remain lower than the vapor pressure at the surface. This vapor pressure gradient is necessary to remove the moisture either by diffusion, convection, or both. Third, there must be a continuous supply of water to the evaporative surface. The first two conditions are strongly influenced by meteorological factors such as air temperature, humidity, wind velocity, and solar radiation, while the third can be controlled by design.

Successful use of evaporation for wastewater disposal requires that evaporation exceed the total water input to the system. Rates of evaporation decrease dramatically during the cold winter months. In the case of evaporative lagoons or evapotranspiration beds, input from precipitation must also be included. Therefore, application of evaporation for wastewater disposal is largely restricted to areas where evaporation rates exceed precipitation rates. These areas occur primarily in the southwestern United States (see Figure 3-1). In other areas, evaporation can be used to augment percolation into the soil.

Transpiration by plants can be used to augment evaporation in soil-covered systems (5)(6). Plants can transpire at high rates, but only during daylight hours of the growing season. During such periods, evapotranspiration rates may exceed ten times the rates measured in Class A evaporation pans (7)(8)(9). However, overall monthly evaporation rates exceed measured evapotranspiration rates. Ratios of evapotranspiration to evaporation (as measured from Class A pans) are estimated to be 0.75

FIGURE 3-1  
 POTENTIAL EVAPORATION VERSUS MEAN ANNUAL PRECIPITATION (4)  
 (inches)

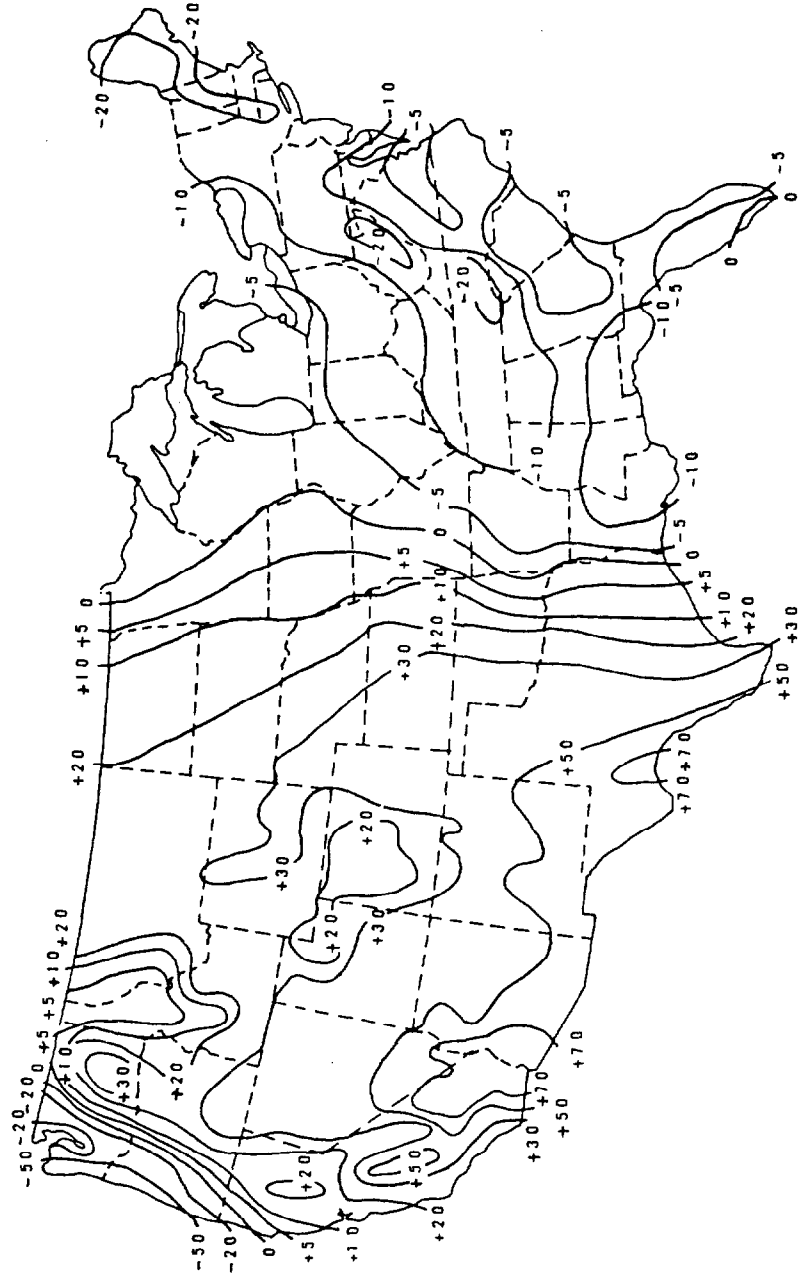

+ Potential Evapotranspiration more than mean annual precipitation  
 - Potential Evapotranspiration less than mean annual precipitation

to 0.8 (6)(7). Therefore, if covered disposal systems are to be used, they must be larger than systems with a free water surface.

### 3.2.3 Wastewater Treatment and Disposal in Surface Waters

Surface waters may be used for the disposal of treated wastewaters if permitted by the local regulatory agency. The capacity of surface waters to assimilate wastewater pollutants varies with the size and type of the body of water. In some cases, because of the potential for human contact as well as the concern for maintaining the quality of lakes, streams, and wetlands, the use of such waters for disposal are limited. Where they can be used, the minimum quality of the wastewater effluent to be discharged is specified by the appropriate water quality agency.

### 3.3 Site Evaluation Strategy

The objective of a site investigation is to evaluate the characteristics of the area for their potential to treat and dispose of wastewater. A good site evaluation is one that provides sufficient information to select the most appropriate treatment and disposal system from a broad range of feasible options. This requires that the site evaluation begin with all options in mind, eliminating infeasible options only as collected site data indicate (see Chapter 2). At the completion of the investigation, final selection of a system from those feasible options is based on costs, aesthetics, and personal preference.

A site evaluation should be done in a systematic manner to ensure the information collected is useful and is sufficient in detail. A suggested procedure is outlined in Table 3-1 and discussed in the following section. This procedure, which can be used to evaluate the feasibility of sites for single dwellings or small clusters of dwellings (up to 10 to 12), is based on the assumption that subsurface soil disposal is the most appropriate method of wastewater disposal. Therefore, the suitability of the soils and other site characteristics for subsurface disposal are evaluated first. If found to be unsuitable, then the site's suitability for other disposal options is evaluated.

TABLE 3-1  
SUGGESTED SITE EVALUATION PROCEDURE

<u>Step</u>	<u>Data Collected</u>
Client Contact	Location and description of lot Type of use Volume and characteristics of wastewater
Preliminary Evaluation	Available resource information (soil maps, geology, etc.) Records of onsite systems in surrounding area
Field Testing	Topography and landscape features Soil profile characteristics Hydraulic conductivity
Other Site Characteristics	If needed, site suitability for evaporation or discharge to surface waters should be evaluated
Organization of Field Information	Compilation of all data into useable form

### 3.3.1 Client Contact

Before performing any onsite testing, it is important to gather information about the site that will be useful in evaluating its potential for treating and disposing of wastewater. This begins with the party developing the lot. The location of the lot and the intended development should be established. The volume and character of the generated wastewater should be estimated. Any wastewater constituents that may pose potential problems in treatment and disposal, such as strong organic wastewaters, large quantities of greases, fats or oils, hazardous and toxic substances, etc., should be identified. This information helps to focus the site evaluation on the important site characteristics.

### 3.3.2 Preliminary Evaluation

The next step is to gather any available resource information about the site. This includes soils, geology, topography, etc., that may be published on maps or in reports. Local records of soil tests, system designs, and reported problems with onsite systems installed in the surrounding area should also be reviewed. This information may lack accuracy, but it can be useful in identifying potential problems or particular features to investigate. A plot plan of the lot and the land immediately adjacent to it should be drawn to a scale large enough so that the information gathered in this and later steps can be displayed on the drawing. The proposed layout of all buildings and other manmade features should also be sketched in.

#### 3.3.2.1 Soil Surveys

Soil surveys are usually found at the local USDA Soil Conservation Service (SCS) office. Also, some areas of the country have been mapped by a state agency and these maps may be located at the appropriate state office. In counties now being mapped, advance field sheets with interpretive tables often can be obtained from the SCS.

Modern soil survey reports are a collection of aerial photographs of the mapping area, usually a county, on which the distribution and kind of soils are indicated. Interpretations about the potential uses of each soil for farming, woodland, recreation, engineering uses, and other nonfarm uses are provided. Detailed descriptions of each soil series found in the area are also given. The maps are usually drawn to a scale of 4 in. to 1 mile. An example of a portion of a soil map is shown in Figure 3-2.

The map symbols for each mapping unit give the name of the soil series, slope, and degree of erosion (10). The soil series name is given a two-letter symbol, the first in upper case, the second in lower case. Slope is indicated by an upper case letter from A to F. A slopes are flat or nearly flat and F slopes are steep. The specific slope range that each letter represents differs from survey to survey. The degree of erosion, if indicated, is given a number representing an erosion class. The classes usually range from 1 to 3, representing slightly eroded to severely eroded phases. The legend for the map symbols is found immediately preceding and following the map sheets in the modern published surveys. An example translation of a map symbol from Figure 3-2 is given in Figure 3-3.

FIGURE 3-2

EXAMPLE OF A PORTION OF A SOIL MAP AS PUBLISHED  
IN A DETAILED SOIL SURVEY (ACTUAL SIZE)

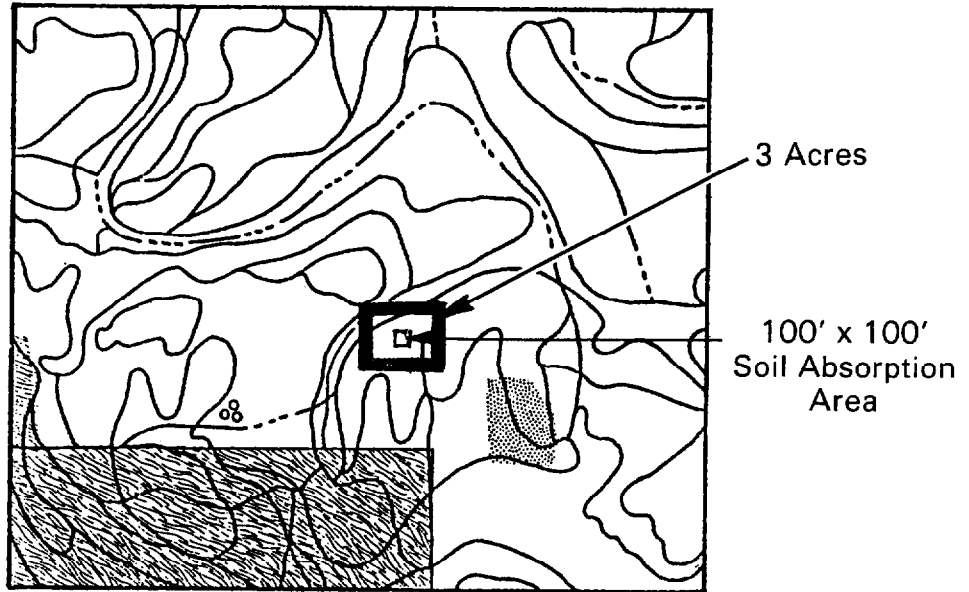
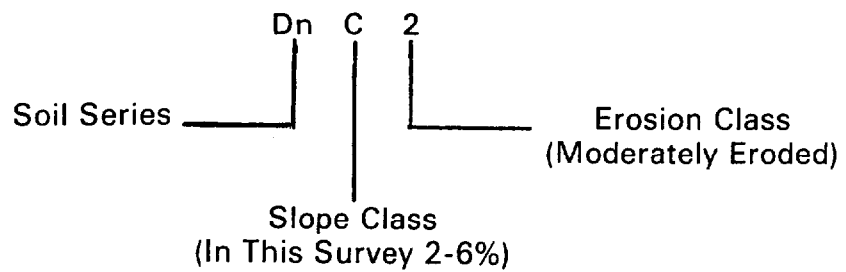

FIGURE 3-3

TRANSLATION OF TYPICAL SOIL MAPPING UNIT SYMBOL





Interpretations about potential uses of each soil series are listed in tables within the text of the report. The soil's suitability for subsurface soil absorption systems and lagoons are specifically indicated. Engineering properties are also listed, often including depth to bedrock, seasonal high water table, percolation rate, shrink-swell potential, drainage potential, etc. Flooding hazard and other important factors are discussed for each mapping unit with the profile descriptions.

While the soil surveys offer good preliminary information about an area, it is not complete nor a substitute for a field study. Because of the scale used, the mapping units cannot represent areas smaller than 2 to 3 acres (8,100 to 12,100 m<sup>2</sup>). Thus, there may be inclusions of soils with significantly different character within mapping units that cannot be indicated. For typical building lots, the map loses accuracy. Therefore, these maps cannot be substituted for onsite testing in most cases.

Limitations ratings used by SCS for septic tank-soil absorption systems are based on conventional trench or bed designs, and thus do not indicate the soil's suitability for other designs. Table 3-2 lists the criteria used in making the limitation ratings. They are based on a soil absorption system with the bottom surface located 2 ft (0.6 m) below the soil surface. In many cases, the limitations can be overcome through proper design. Therefore, the interpretations should be used only as a guide.

The information provided by the soil survey should be transferred to the site drawing along with other important information. An example for a parcel is shown in Figure 3-4. Information for each of the soil sites shown on Figure 3-4 is presented in Table 3-3.

#### 3.3.2.2 U.S. Geological Survey Quadrangles

Quadrangles published by the U.S. Geological Survey may be useful in estimating slope, topography, local depressions or wet areas, rock outcrops, and regional drainage patterns and water table elevations. These maps are usually drawn to a scale of 1:24,000 (7.5 minute series) or 1:62,500 (15 minute series). However, because of their scale, they are of limited value for evaluating small parcels.

TABLE 3-2

SOIL LIMITATIONS RATINGS USED BY SCS  
FOR SEPTIC TANK/SOIL ABSORPTION FIELDS  
[Modified after (10)]

Property	Limits			Restrictive Feature
	Slight	Moderate	Severe	
USDA Texture	----	----	Ice	Permafrost
Flooding	None, Protected	Rare	Common	Floods
Depth to Bedrock, in.	>72	40-72	<40	Depth to Rock
Depth to Cemented Pan, in.	>72	40-72	<40	Depth to Cemented Pan
Depth to High Water Table, ft below ground	>6	4-6	<4	Ponding, Wetness
Permeability, in./hr				
24-60 in. layer	2.0-6.0	0.6-2.0	<0.6	Slow Perc. Rate
layers <24 in.	---	---	>6.0	Poor Filter
Slope, percent	0-8	8-15	>15	Slope
Fraction >3 in., percent by wt	<25	25-50	>50	Large Stones

### 3.3.2.3 Local Records

Soil test reports and records of reported failure of onsite systems from the surrounding area may be a source of valuable information. The soil test reports can provide an indication of soil types and variability. Performance of systems may be determined from the reported failures. These records are usually available from the local regulatory agency.

FIGURE 3-4

PLOT PLAN SHOWING SOIL SERIES BOUNDARIES  
FROM SOIL SURVEY REPORT

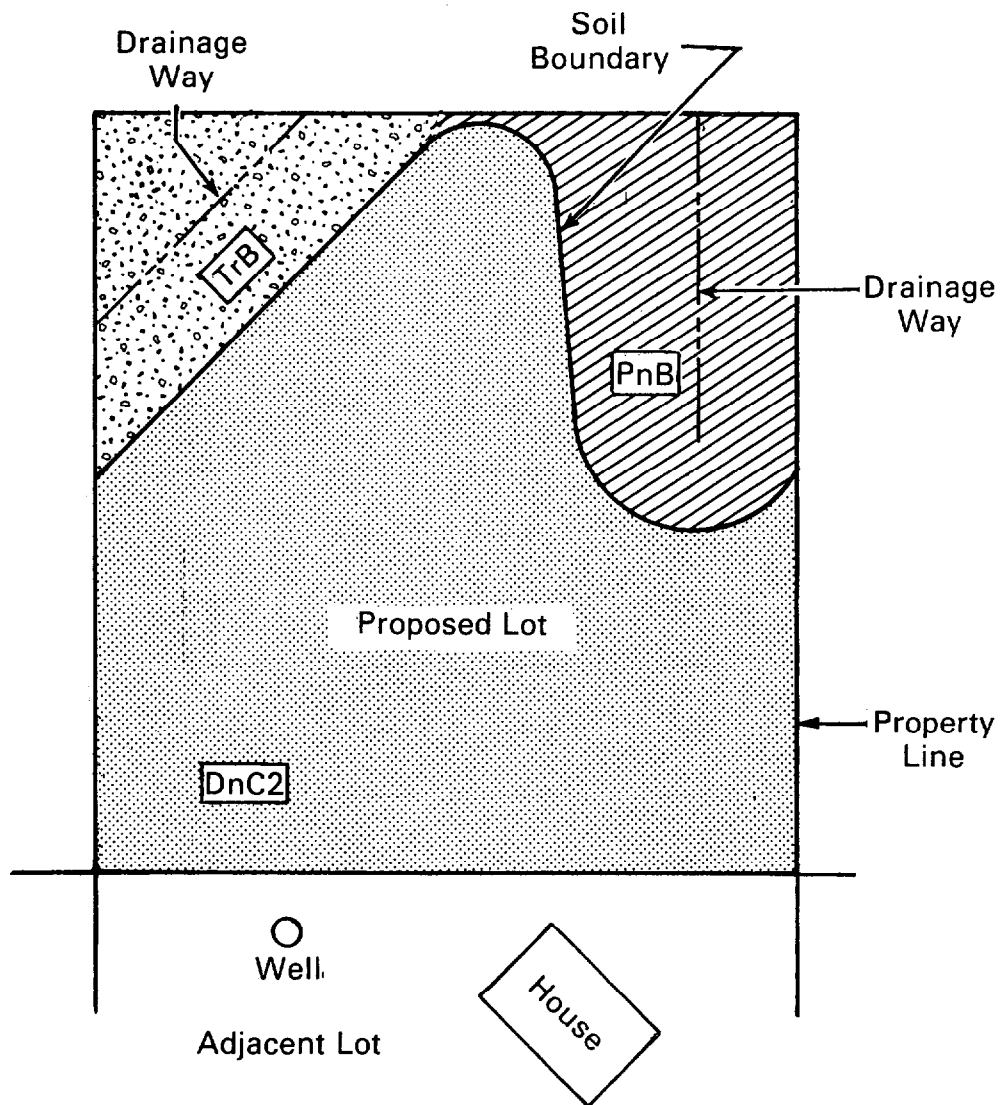

TABLE 3-3  
SOIL SURVEY REPORT INFORMATION  
FOR PARCEL IN FIGURE 3-4

Map Symbol	Soil Series	Slope %	Soil Absorption Limitation Rating	Flood Hazard	Depth to High Water Table ft	Depth to Bedrock ft	Permeability	
							Depth in.	Perm. in./hr
DnC2	Dodge	2-6	Moderate	No	>5	5-10	0-40 40-60	0.63-2.0 2.0-6.3
TrB	Troxel	2-6	Severe	Yes	3-5	>10	0-60	0.63-20
PnB	Plano	2-6	Moderate	No	3-5	>10	0-41 41-60	0.63-2.0 2.0-6.3

### 3.3.3 Field Testing

Field testing begins with a visual survey of the parcel to locate potential sites for subsurface soil absorption. Soil borings are made in the potential sites to observe the soil characteristics. Percolation tests may be conducted in those soils that appear to be well suited. If no potential sites can be found from either the visual survey, soil borings, or percolation tests, then other means of disposal should be investigated.

#### 3.3.3.1 Visual Survey

A visual survey is made to locate the areas on the lot with the greatest potential for subsurface soil absorption. The location of any depressions gullies, steep slopes, rocks or rock outcrops, or other obvious land and surface features are noted and marked on the plot plan. Vegetation types are also noted that may indicate wetness or shallow soils. Locations and distances from a permanent benchmark to lot lines, wells, surface waters, buildings, and other features or structures are also marked on the plot plan (see Figure 3-5). If a suitable area cannot be

FIGURE 3-5  
PLOT PLAN SHOWING SURFACE FEATURES

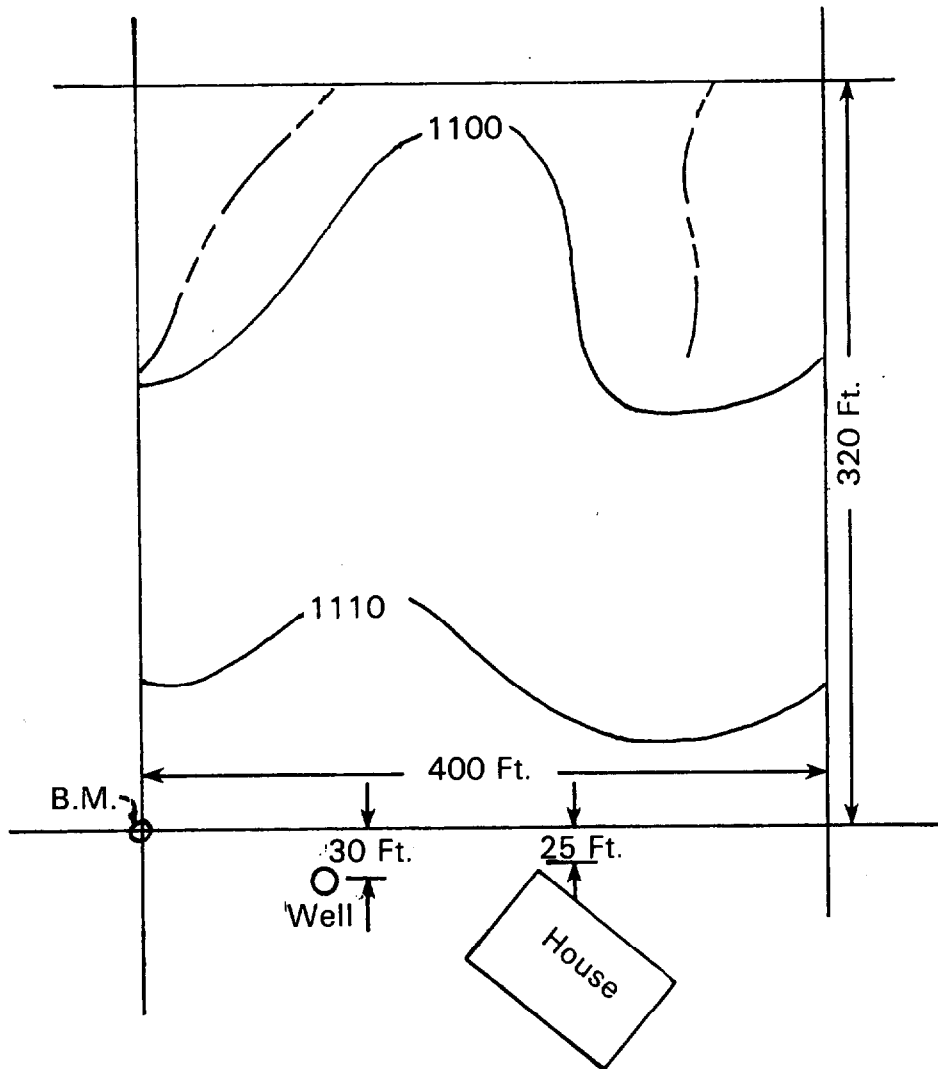

found for a subsurface soil absorption system based on this information other disposal options must be considered (see Chapter 2). The remainder of the field testing can be altered accordingly.

### 3.3.3.2 Landscape Position

The landscape position and landform for each suitable area should be noted. Figure 3-6 can be used as a guide for identifying landscape positions. This information is useful in estimating surface and subsurface drainage patterns. For example, hilltops and sideslopes can be expected to have good surface and subsurface drainage, while depressions and footslopes are more likely to be poorly drained.

### 3.3.3.3 Slope

The type and degree of slope of the area should be determined. The type of slope indicates what surface drainage problems may be expected. For example, concave slopes cause surface runoff to converge, while convex slopes disperse the runoff (see Figure 3-6).

Some treatment and disposal systems are limited by slopes. Therefore, slope measurement is important. Land slopes can be expressed in several ways (see Figure 3-7):

1. PERCENT OF GRADE - The feet of vertical rise or fall in 100 ft horizontal distance.
2. SLOPE - The ratio of vertical rise or fall to horizontal distance.
3. ANGLE - The degrees and minutes from horizontal.
4. TOPOGRAPHIC ARC - The feet of vertical rise or fall in 66 ft (20 m) horizontal distance.

Land slopes are usually determined by measuring the slope of a line parallel to the ground with an Abney Level either at eye height or at some other fixed height above the ground. If an ordinary hand level is used, then slopes are determined by horizontal line of sight which give changes in elevation for specific horizontal distances. A hand level is limited in use because it is best suited for slope determinations up grade only, but has the advantage that only one person is needed for mapping slopes. Three methods of slope determinations are discussed below.

FIGURE 3-6  
LANDSCAPE POSITIONS

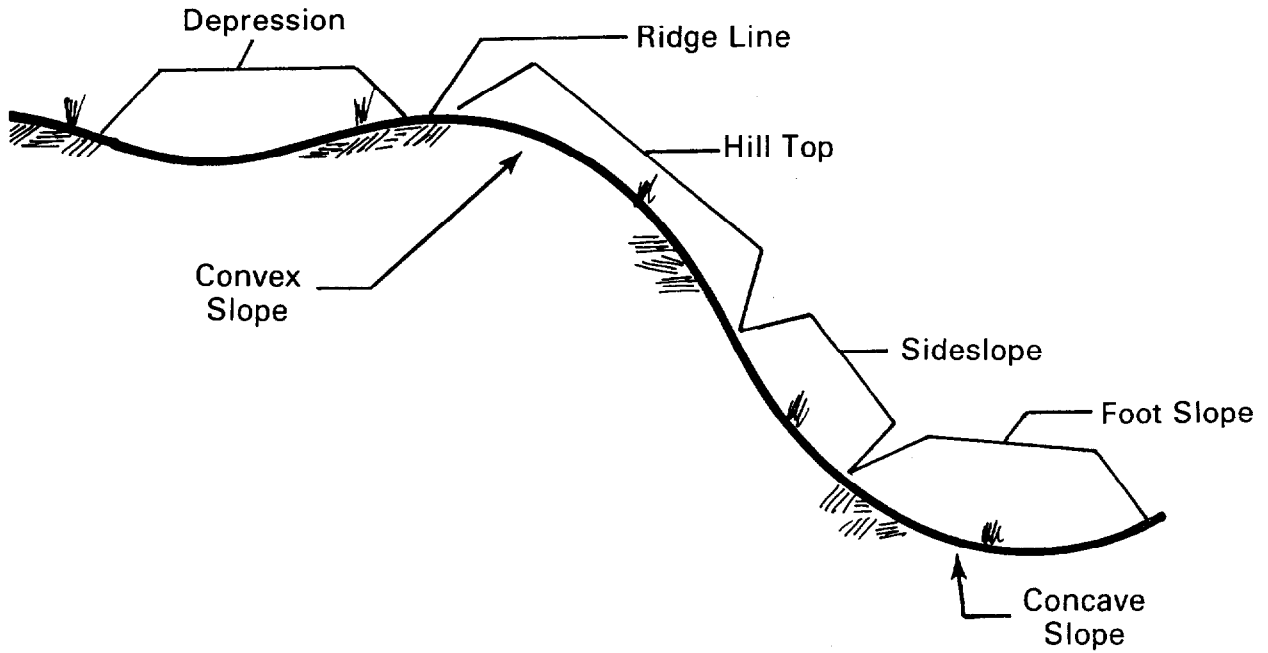
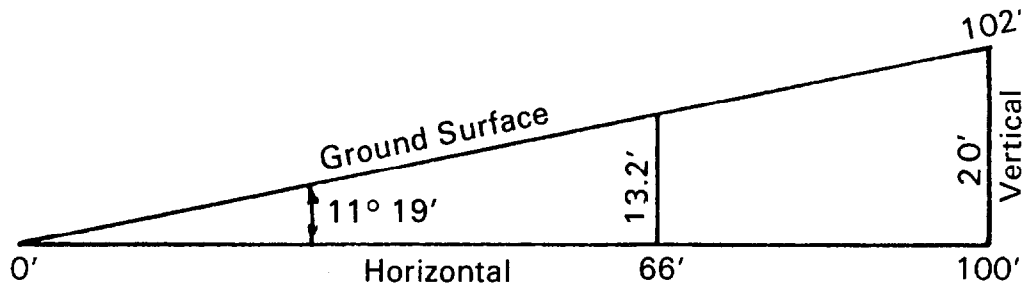

FIGURE 3-7  
METHODS OF EXPRESSING LAND SLOPES (10)



Percent of Grade - 20  
Slope-1:5  
Angle - 11° 19'  
Topographic Arc - 13.2

Instrument Supported - Abney Level: For accurate slope determinations, notch two sticks or cut forked sticks so they will hold the level 5 ft (1.5 m) above the ground. Rest the level in the notch or fork and sight to the notch or fork of the other stick held by another person at a point on the slope. The land slope is read directly in percent on the Abney Level.

Abney Level: On level ground, sight the person working with you to determine the point of intersection of your line of sight on him when the instrument is in position for use as a hand level (zero level position). When he is on the slope, sight the same point on the person assisting you and read the slope directly.

Hand Level: Height of eye must be determined. Then sight the point of interception with the ground surface and determine, by tape measurement or pacing, the ground surface distance between the sighting point and the point of intercept. To calculate land slope in percent, divide your height of eye by the ground surface distance and multiply by 100.

Using one of the above procedures or other surveying methods, slopes at selected sites can be determined so that topography can be mapped. The number of sites needed will depend on the complexity of slopes. Slope determinations should be made at each apparent change in slope at known locations so steep slope areas can be accurately drawn. Experience will be required for proficiency and accuracy in mapping. Steep slope areas in natural topography have irregular form and curved boundaries. Uniform boundaries having straight lines and angular corners indicate man-altered conditions. For large areas it may be necessary to draw contour lines so that slopes at different points in the plot can be determined.

#### 3.3.3.4 Soil Borings

Observation and evaluation of soil characteristics can best be determined from a pit dug by a backhoe or other excavating equipment. However, an experienced soil tester can do a satisfactory job by using a hand auger or probe. Both methods are suggested. Hand tools can be used to determine soil variability over the area and pits used to describe the various soil types found.

Soil pits should be prepared at the perimeter of the expected soil absorption area. Pits prepared within the absorption area often settle after the system has been installed and may disrupt the distribution network. If hand augers are used, the holes may be made within the



absorption area. Sufficient borings or pits should be made to adequately describe the soils in the area, and should be deep enough to assure that a sufficient depth of unsaturated soil exists below the proposed bottom elevation of the absorption area. Variable soil conditions may require many pits.

Since in some cases subtle differences in color need to be recognized, it is often advantageous to prepare the soil pit so the sun will be shining on the face during the observation period. Natural light will give true color interpretations. Artificial lighting should not be used.

### 3.3.3.5 Soil Texture

Texture is one of the most important physical properties of soil because of its close relationship to pore size, pore size distribution, and pore continuity. It refers to the relative proportion of the various sizes of solid particles in the soil that are smaller than 2 mm in diameter. The soil texture is determined in the field by rubbing a moist sample between the thumb and forefinger. A water bottle is useful for moisturizing the sample. The grittiness, "silkeness," or stickiness can be interpreted as being caused by the soil separates of sand, silt, and clay. It is extremely helpful to work with some known samples to gain experience with field texturing.

While laboratory analysis of soil texture is done routinely by many laboratories, field texturing can give as good information as laboratory data and therefore expenditures of time and money for laboratory analyses are not necessary. To determine the soil texture, moisten a sample of soil about one-half to one inch in diameter. There should be just enough moisture so that the consistency is like putty. Too much moisture results in a sticky material, which is hard to work. Press and squeeze the sample between the thumb and forefinger. Gradually press the thumb forward to try to form a ribbon from the soil (see Figure 3-8). By using this procedure, the texture of the soil can be easily described.

Table 3-4 and Figures 3-9 and 3-10 describe the feeling and appearance of the various soil textures for a general soil classification.

FIGURE 3-8

PREPARATION OF SOIL SAMPLE FOR FIELD  
DETERMINATION OF SOIL TEXTURE



(A) Moistening Sample



(B) Forming Cast



(C) Ribboning

TABLE 3-4  
TEXTURAL PROPERTIES OF MINERAL SOILS

Soil Class	Feeling and Appearance	
	Dry Soil	Moist Soil
Sand	Loose, single grains which feel gritty. Squeezed in the hand, the soil mass falls apart when the pressure is released.	Squeezed in the hand, it forms a cast which crumbles when touched. Does not form a ribbon between thumb and forefinger.
Sandy Loam	Aggregates easily crushed; very faint velvety feeling initially but with continued rubbing the gritty feeling of sand soon dominates.	Forms a cast which bears careful handling without breaking. Does not form a ribbon between thumb and forefinger.
Loam	Aggregates are crushed under moderate pressure; clods can be quite firm. When pulverized, loam has velvety feel that becomes gritty with continued rubbing. Casts bear careful handling.	Cast can be handled quite freely without breaking. Very slight tendency to ribbon between thumb and forefinger. Rubbed surface is rough.
Silt Loam	Aggregates are firm but may be crushed under moderate pressure. Clods are firm to hard. Smooth, flour-like feel dominates when soil is pulverized.	Cast can be freely handled without breaking. Slight tendency to ribbon between thumb and forefinger. Rubbed surface has a broken or rippled appearance.
Clay Loam	Very firm aggregates and hard clods that strongly resist crushing by hand. When pulverized, the soil takes on a somewhat gritty feeling due to the harshness of the very small aggregates which persist.	Cast can bear much handling without breaking. Pinched between the thumb and forefinger, it forms a ribbon whose surface tends to feel slightly gritty when dampened and rubbed. Soil is plastic, sticky and puddles easily.
Clay	Aggregates are hard; clods are extremely hard and strongly resist crushing by hand. When pulverized, it has a grit-like texture due to the harshness of numerous very small aggregates which persist.	Casts can bear considerable handling without breaking. Forms a flexible ribbon between thumb and forefinger and retains its plasticity when elongated. Rubbed surface has a very smooth, satin feeling. Sticky when wet and easily puddled.

FIGURE 3-9

SOIL TEXTURE DETERMINATION BY HAND: PHYSICAL APPEARANCE OF VARIOUS SOIL TEXTURES







	Dry	Moist
Sandy Loam	 Weak Aggregates	 No Ribbon; Non-Plastic Cast
Silt Loam	 Firm Aggregates	 Very Slight Ribbing Tendency; Moderately Plastic Cast
Clay	 Hard Aggregates	 Ribbons Easily; Plastic Cast

FIGURE 3-10

COMPARISON OF RIBBONS AND CASTS OF SANDY LOAM  
AND CLAY (RIBBONS ABOVE, CASTS BELOW)

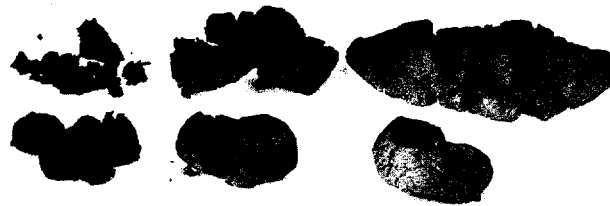

If the soil sample ribbons (loam, clay loam, or clay), it may be desirable to determine if sand or silt predominate. If there is a gritty feel and a lack of smooth talc-like feel, then sand very likely predominates. If there is a lack of a gritty feel but a smooth talc-like feel, then silt predominates. If there is not a predominance of either the smooth or gritty feel, then the sample should not be called anything other than a clay, clay loam, or loam. If a sample feels quite smooth with little or no grit in it, and will not form a ribbon, the sample would be called silt loam.

Beginning at the top or bottom of the pit sidewall, obvious changes in texture with depth are noted. Boundaries that can be seen are marked. The texture of each layer or horizon is determined and the demarcations of boundaries changed as appropriate. When the textures have been determined for each layer, the depth, thickness, and texture of each layer is recorded (see Figure 3-11).

#### 3.3.3.6 Soil Structure

Soil structure has a significant influence on the soil's acceptance and transmission of water. Soil structure refers to the aggregation of soil particles into clusters of particles, called peds, that are separated by surfaces of weakness. These surfaces of weakness open planar pores between the peds that are often seen as cracks in the soil. These planar pores can greatly modify the influence of soil texture on water movement. Well-structured soils with large voids between peds will transmit water more rapidly than structureless soils of the same texture, particularly if the soil has become dry before the water is added. Fine-textured, massive soils (soils with little structure) have very slow percolation rates.

FIGURE 3-11

EXAMPLE PROCEDURE FOR COLLECTING  
SOIL PIT OBSERVATION INFORMATION

Depth (Ft.)	Texture	Structure	Color	Soil Saturation
0	Silt Loam	Granular	Brown	None
		Platy		
2	Silty Clay Loam	Blocky		
	Clay Loam			
4	Sandy Loam	Platy		
6	↓	Massive		
8				
10				
12				
14				

If a detailed analysis of the soil structure is necessary, the sidewall of the soil pit should be carefully examined, using a pick or similar device to expose the natural cleavages and planes of weakness. Cracks in the face of the soil profile are indications of breaks between soil peds. The shapes created by the cracks should be compared to the shapes shown in Figure 3-12. If cracks are not visible, a sample of soil should be carefully picked out and, by hand, carefully separated into the structural units until any further breakdown can only be achieved by fracturing.

Since the structure can significantly alter the hydraulic characteristics of soils, more detailed descriptions of soil structure are sometimes desirable. Size and grade of durability of the structural units provide useful information to estimate hydraulic conductivities. Descriptions of types and classes of soil structure used by SCS are given in Appendix A. Grade descriptions are given in Table 3-5. The type, size, and grade of each horizon or zone is recorded in Figure 3-11.

#### 3.3.3.7 Soil Color

The color and color patterns in soil are good indicators of the drainage characteristics of the soil. Soil properties, location in the landscape, and climate all influence water movement in the soil. These factors cause some soils to be saturated or seasonally saturated, affecting their ability to absorb and treat wastewater. Interpretation of soil color aids in identifying these conditions.

Color may be described by estimating the true color for each horizon or by comparing the soil with the colors in a soil color book. In either case, it is particularly important to note the colors or color patterns.

Pick up some soil and, without crushing, observe the color. It is important to have good sunlight and know the moisture status of the sample. If ped faces are dry, some water applied from a mist bottle will allow observation of moist colors.

Though it is often adequate to speak of soil colors in general terms, there is a standard method of describing colors using Munsell color notation. This notation is used in soil survey reports and soil description. Hue is the dominant spectral color and refers to the lightness or darkness of the color between black and white. Chroma is the relative purity or strength of the color, and ranges from gray to a bright color of that hue. Numbers are given to each of the variables and a verbal description is also given. For example, 10YR 3/2 corresponds to a color hue of 10YR value of 3 and chroma 2. This is a very dark grayish brown.

FIGURE 3-12  
 TYPES OF SOIL STRUCTURE

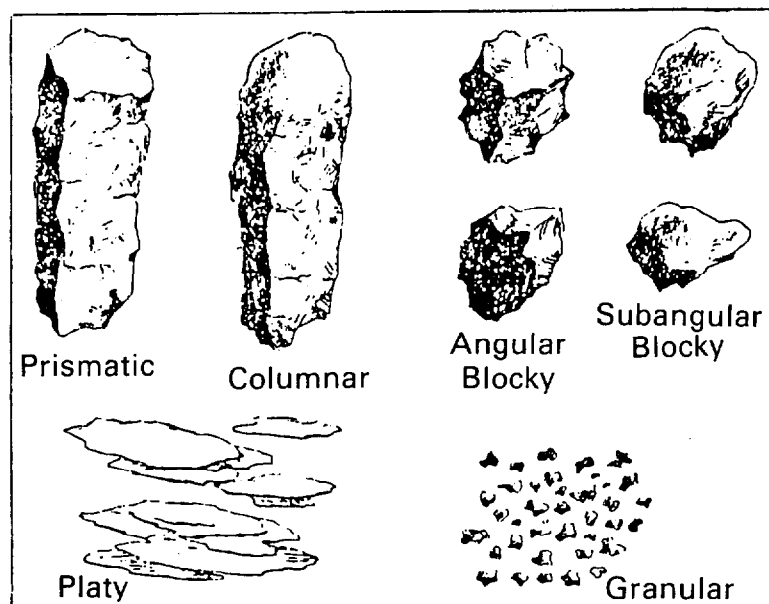

TABLE 3-5  
 GRADES OF SOIL STRUCTURE

<u>Grade</u>	<u>Characteristics</u>
Structureless	No observable aggregation.
Weak	Poorly formed and difficult to see. Will not retain shape on handling.
Moderate	Evident but not distinct in undisturbed soil. Moderately durable on handling.
Strong	Visually distinct in undisturbed soil. Durable on handling.



If a soil color book is used to determine soil colors, hold the soil and book so the sun shines over your shoulder. Match the soil color with the color chip in the book. Record the hue, chroma and value, and the color name.

Mottling in soils is described by the color of the soil matrix and the color or colors, size, and number of the mottles. Each color may be given a Munsell designation and name. However, it is often sufficient to say the soil is mottled. A classification of mottles used by the USDA is shown in Table 3-6. Some examples of soil mottling are shown on the inside back cover of this manual.

TABLE 3-6  
DESCRIPTION OF SOIL MOTTLES (10)

<u>Character</u>	<u>Class</u>	<u>Limit</u>
Abundance	Few	<2% of exposed face
	Common	2-20% of exposed face
	Many	>20% of exposed face
Size	Fine	<5mm longest dimension
	Medium	5-15mm longest dimension
	Coarse	>15mm longest dimension
Contrast	Faint	Recognized only by close observation
	Distinct	Readily seen but not striking
	Prominent	Obvious and striking

### 3.3.3.8 Seasonally Saturated Soils

Seasonally saturated soils can usually be detected by soil borings made during the wet season or by the presence of mottled soils (see 3.3.3.7). For large cluster systems or for developments where each dwelling is served by an onsite system, the use of observation wells may be justified. They are constructed as shown in Figure 3-13. The well should be placed in, but not extended through, the horizon that is to be monitored. More than one well in each horizon that may become seasonally saturated is desirable. The wells are monitored over a normal wet season by observing the presence and duration of water in the well. If water remains in the well for several days, the water level elevation is measured and assumed to be the elevation of the seasonally saturated soil horizon.

FIGURE 3-13

TYPICAL OBSERVATION WELL FOR  
DETERMINING SOIL SATURATION

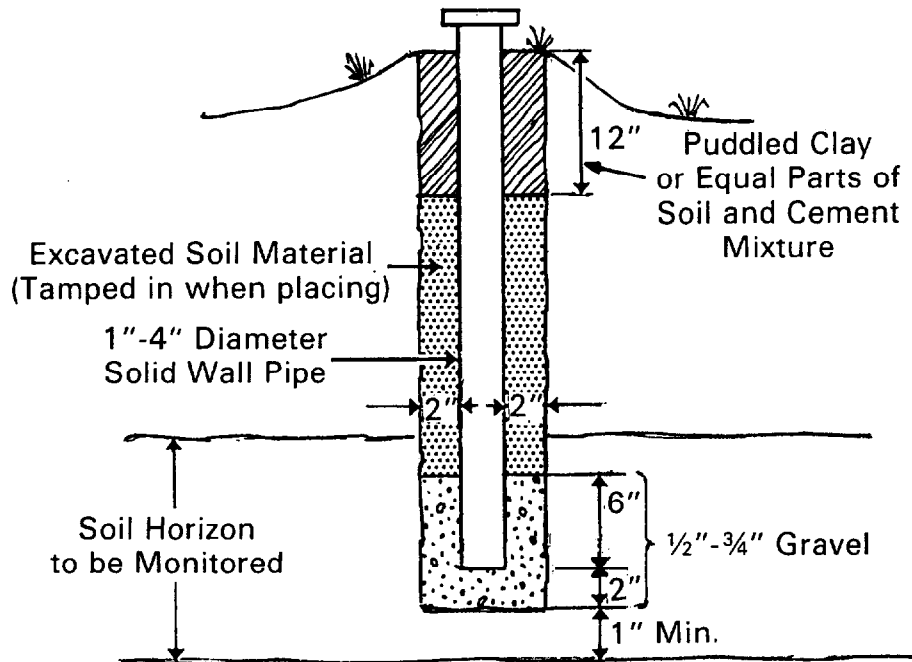

3.3.3.9 Other Selected Soil Characteristics

Soil bulk density is related to porosity and the movement of water. High bulk density is an indication of low porosity and restricted flow of water. Relative bulk densities of different soil horizons can be detected in the field by pushing a knife or other instrument into each horizon. If one horizon offers considerably more resistance to penetration than the others, its bulk density is probably higher. However, in some cases, cementing agents between soil grains or peds may be the cause of resistance to penetration.

Swelling clays, particularly montmorillonite clays, can seal off soil pores when wet. They can be detected during field texturing of the soil by their tendency to be more sticky and plastic when wet.

### 3.3.3.10 Hydraulic Conductivity

Several methods of measuring the hydraulic conductivity of soils have been developed (1)(11). The most commonly used test is the percolation test. When run properly, the test can give an approximate measure of the soil's saturated hydraulic conductivity. However, the percolation of wastewater through soil below soil disposal systems usually occurs through unsaturated soils. Therefore, empirical factors must be used to estimate unsaturated conductivities. The unsaturated hydraulic conductivities can vary dramatically from the saturated hydraulic conductivity with changes in soil characteristics and moisture content (see Appendix A).

The percolation test is often criticized because of its variability and failure to measure the hydraulic conductivity accurately. Percolation tests conducted in the same soils can vary by 90% or more (1)(11)(12)(13)(14). Reasons for the large variability are attributed to the procedure used, the soil moisture conditions at the time of the test, and the individual performing the test. Despite these shortcomings, the percolation test can be useful if used together with the soil borings data. The test can be used to rank the relative hydraulic conductivity of the soil. Estimated percolation rates for various soil textures are given in Table 3-7.

TABLE 3-7  
ESTIMATED HYDRAULIC CHARACTERISTICS OF SOIL (15)

<u>Soil Texture</u>	<u>Permeability</u> in./hr	<u>Percolation</u> min/in.
Sand	>6.0	<10
Sandy loams Porous silt loams Silty clay loams	0.2-6.0	10-45
Clays, compact Silt loams Silty clay loams	<0.2	>45

If test results agree with this table, the test and boring data are probably correct and can be used in design. If not, either the test was run improperly or soil structure or clay mineralogy have a significant effect on the hydraulic conductivity. For example, if the texture of a soil is determined to be a clay loam, the estimated percolation rate is slower than 45 min/in. (18 min/cm). If the measured percolation rate is 15 min/in. (6 min/cm), however, either the texture is incorrect or the soil has strong structure with large cracks between peds. The tester should be cautious in such soils because the unsaturated hydraulic conductivity may be many times less. Expandable clays may be present that could close many of the pores.

Several percolation test procedures are used (11) (16). The most common procedure is the falling head test (11). Though less reproducible than other procedures, it is simple to perform in the field (11) (12). The falling head procedure is outlined in Table 3-8. A diagram of a "percometer" designed to simplify the testing is illustrated in Figure 3-14. For a discussion of other methods see the National Environmental Health Association's "On-Site Wastewater Management" (16).

Data collected from the percolation test can be tabulated using a form similar to the one illustrated in Figure 3-15.

### 3.3.4 Other Site Characteristics

If subsurface disposal does not appear to be a viable option or cost-effective, other methods of disposal are evaluated (see Chapter 2). Evaporation and discharge to surface waters are other options to investigate. Each requires further site evaluation.

#### 3.3.4.1 Site Evaluation of Evaporation Potential

Evaporation and evapotranspiration can be used as the sole means of disposal or as a supplement to soil absorption. To be effective, evaporation should exceed precipitation in the area. The difference between evaporation and precipitation rates provides estimates of quantities of water that can be evaporated from a free water surface.

Weather data can be obtained from local weather stations and the National Oceanic and Atmosphere Administration (NOAA). Rainfall and snowfall measurements are available from NOAA for thousands of weather stations throughout the country. Many local agencies also maintain records. A critical wet year is typically used for design based on at least 10 years of records (18).

## TABLE 3-8

### FALLING HEAD PERCOLATION TEST PROCEDURE

#### 1. Number and Location of Tests

Commonly a minimum of three percolation tests are performed within the area proposed for an absorption system. They are spaced uniformly throughout the area. If soil conditions are highly variable, more tests may be required.

#### 2. Preparation of Test Hole

The diameter of each test hole is 6 in., dug or bored to the proposed depths at the absorption systems or to the most limiting soil horizon. To expose a natural soil surface, the sides of the hole are scratched with a sharp pointed instrument and the loose material is removed from the bottom of the test hole. Two inches of 1/2 to 3/4 in. gravel are placed in the hole to protect the bottom from scouring action when the water is added.

#### 3. Soaking Period

The hole is carefully filled with at least 12 in. of clear water. This depth of water should be maintained for at least 4 hr and preferably overnight if clay soils are present. A funnel with an attached hose or similar device may be used to prevent water from washing down the sides of the hole. Automatic siphons or float valves may be employed to automatically maintain the water level during the soaking period. It is extremely important that the soil be allowed to soak for a sufficiently long period of time to allow the soil to swell if accurate results are to be obtained.

In sandy soils with little or no clay, soaking is not necessary. If, after filling the hole twice with 12 in. of water, the water seeps completely away in less than ten minutes, the test can proceed immediately.

#### 4. Measurement of the Percolation Rate

Except for sandy soils, percolation rate measurements are made 15 hr but no more than 30 hr after the soaking period began. Any soil that sloughed into the hole during the soaking period is removed and the water level is adjusted to 6 in. above the gravel (or 8 in. above the bottom of the hole). At no time during the test is the water level allowed to rise more than 6 in. above the gravel.

Immediately after adjustment, the water level is measured from a fixed reference point to the nearest 1/16 in. at 30 min intervals. The test is continued until two successive water level drops do not vary by more than 1/16 in. At least three measurements are made.

After each measurement, the water level is readjusted to the 6 in. level. The last water level drop is used to calculate the percolation rate.

In sandy soils or soils in which the first 6 in. of water added after the soaking period seeps away in less than 30 min, water level measurements are made at 10 min intervals for a 1 hr period. The last water level drop is used to calculate the percolation rate.

#### 5. Calculation of the Percolation Rate

The percolation rate is calculated for each test hole by dividing the time interval used between measurements by the magnitude of the last water level drop. This calculation results in a percolation rate in terms of min/in. To determine the percolation rate for the area, the rates obtained from each hole are averaged. (If tests in the area vary by more than 20 min/in., variations in soil type are indicated. Under these circumstances, percolation rates should not be averaged.)

Example: If the last measured drop in water level after 30 min is 5/8 in., the percolation rate = (30 min)/(5/8 in.) = 48 min/in.

FIGURE 3-14

CONSTRUCTION OF A PERCOMETER

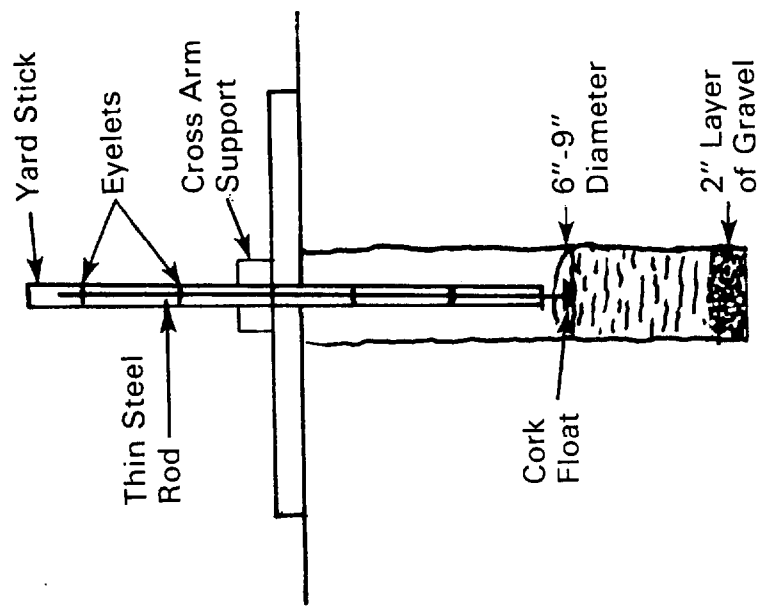

(a) Floating Indicator

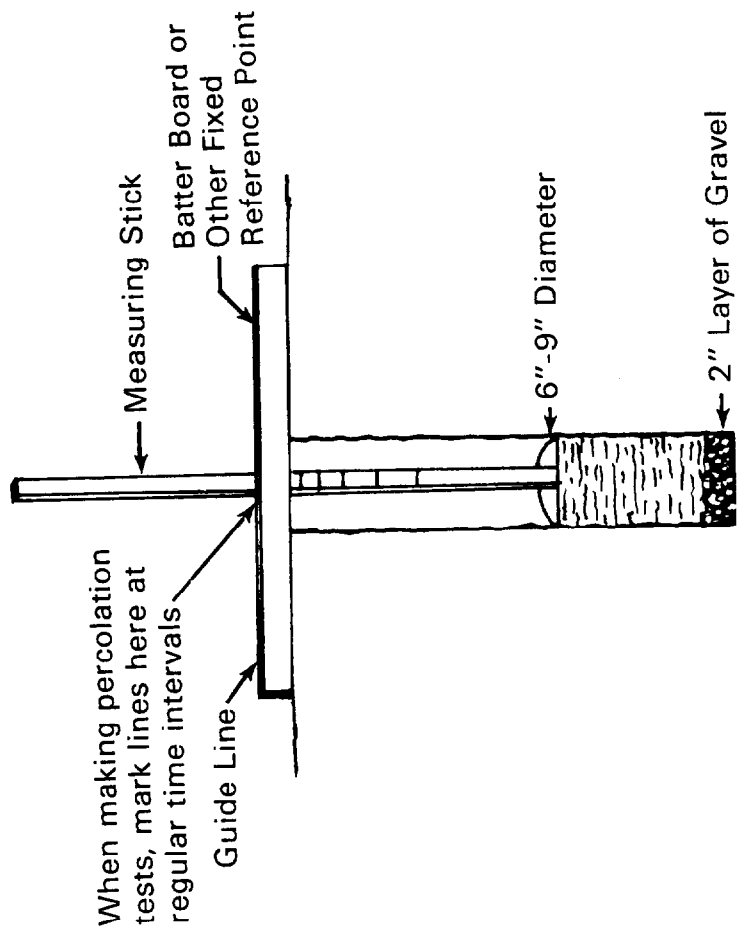

(b) Fixed Indicator

FIGURE 3-15

PERCOLATION TEST DATA FORM (17)

Percolation test

Location Lot 105, High Point Heights Subdivision

Test hole number 3

Depth to bottom of hole 28 inches. Diameter of hole 6 inches.

Depth, inches	Soil texture
<u>0-4</u>	<u>blk top soil</u>
<u>4-12</u>	<u>brn sl</u>
<u>12-28</u>	<u>brn scl</u>

Percolation test by C. J. Tester

Date of test 6/28/80

Time	Time Interval, minutes	Measurement, inches	Drop in water level, inches	Percolation rate, minutes per inch	Remarks
9:30	-	44	-		
10:00	30	43	1		
10:20	20	43	1		
10:50	30	43 1/4	3/4		
11:20	30	43 1/16	15/16		
12:00	40	43 1/4	3/4		
12:30	30	43 3/16	13/16		
1:00	30	43 5/16	11/16		
1:30	30	43 5/16	11/16	44	

Percolation rate = 44 minutes per inch.

Establishing evaporation data at a specific location can be a more difficult problem. Measurements of Class A pan evaporation rates are reported for all of the states by NOAA in the publication, "Climatological Data," U.S. Department of Commerce, available in depository libraries for government documents at major universities in each state. Pan evaporation measurements are made at a few (5 to 30) weather stations in each state. Data for the winter months are often omitted because this method cannot be used under freezing weather conditions. The critical period of the year for design of systems for permanent homes is in the winter. Obtaining representative winter evaporation data is probably the most difficult part of design analysis. Application of evaporation systems is most favorable in the warm, dry climates of the southwestern United States. For these areas, pan evaporation data are available for the complete year. The analysis of evaporative potential for cooler, semi-arid regions, such as eastern Washington and Oregon, Utah, Colorado, and similar areas, requires that winter data be established by means other than pan evaporation measurements, since these data are generally not available.

One method for establishing representative winter evaporation data is to take measurements on buried lysimeters. Another method is to use empirical formulations such as the Penman formula (18). The Penman formula has been shown to give results comparable to measured winter values (5).

#### 3.3.4.2 Site Evaluation for Surface Water Discharge

For surface water disposal to be a viable option, access to a suitable surface body of water must be available. Onsite investigations must locate the body of water, identify it, and determine the means by which access can be gained. Since discharges to surface waters are usually regulated, the local water quality agency must be contacted to learn if discharge of wastewater into that body of water is permitted and, if so, what effluent standards must be met.

#### 3.3.5 Organizing the Site Information

As the site information is collected, it is organized so that it can be easily used to check site suitability for any of the various systems discussed in this manual. One such method of organization is shown in Figure 3-16. In this example, two soil observations have been made. The number of soil observations varies. It is important that all pertinent site information be presented in a clear fashion to provide sufficient information to the designer of the system without making additional site visits.



FIGURE 3-16

COMPILATION OF SOILS AND SITE INFORMATION  
(INFORMATION INCLUDES TOPOGRAPHIC, SOIL SURVEY,  
ONSITE SLOPE AND SOIL PIT OBSERVATIONS)

Name T. B. Resident Site evaluator C.J. Tester  
Address LOT 105, High Points Heights Address Lake City, U.S.A.  
Waste water quantity 4.50 gpd

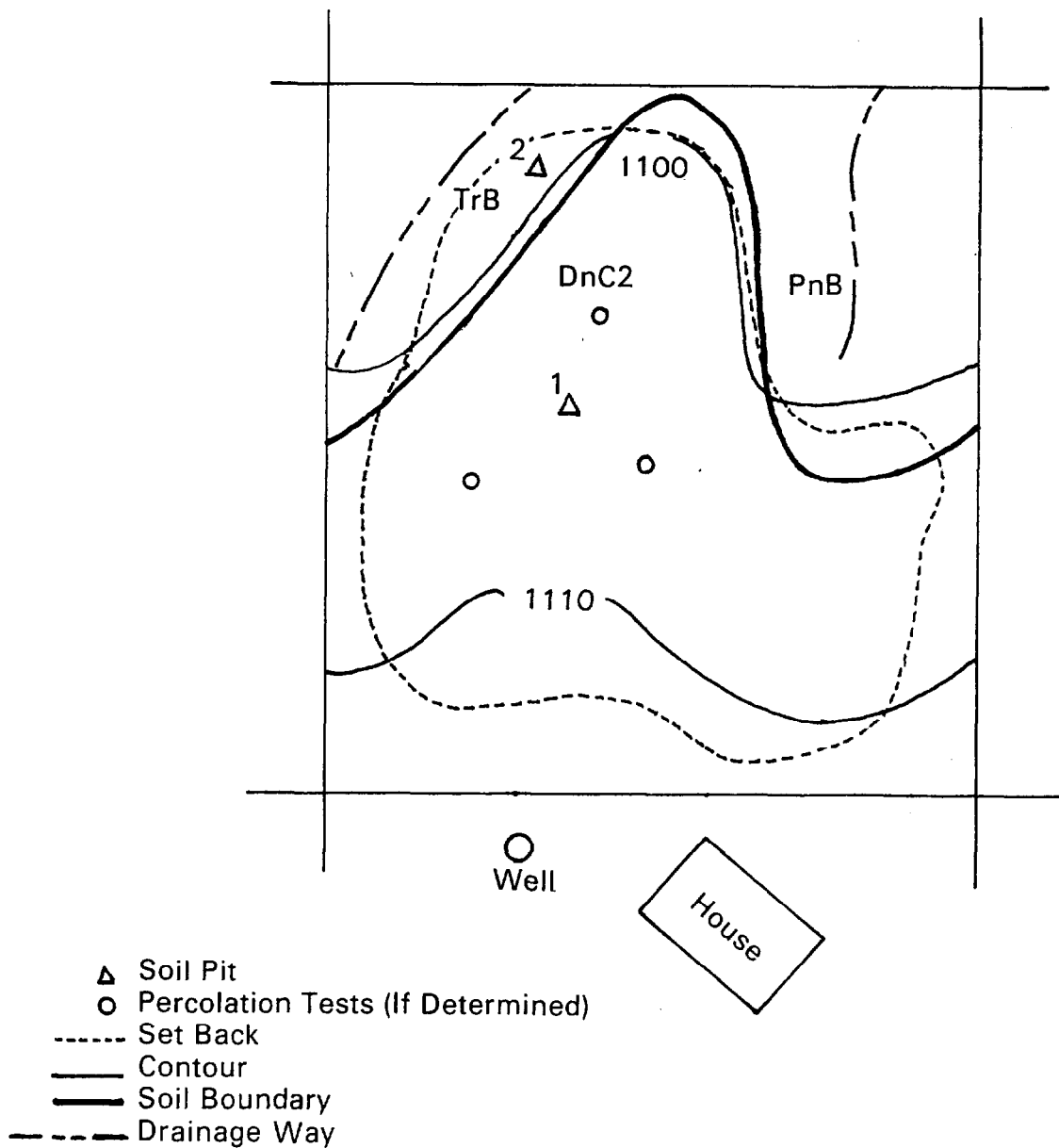

FIGURE 3-16 (continued)

Name: Resident  
 Soil Pit No. 1

Depth (Ft.)	Texture	Structure	Color	Soil Saturation
0	Silt Loam	Granular	Brown	None
		Platy		
2	Silty Clay Loam	Blocky		
	Clay Loam			
4	Sandy Loam	Platy		
6	↓	Massive		
8				
10				
12				
14				

Soil Map Unit - DnC2  
 Slope - 6%  
 Landscape Position - Side Slope  
 Landscape Type - Plane to Concave

FIGURE 3-16 (continued)

Name: Resident

Soil Pit No. 2

	Texture	Structure	Color	Soil Saturation
0	Silt Loam	Blocky	Brown	
2		Granular	Black	
4	Silty Clay Loam	Blocky	Brown	
6	Silt Loam		Massive	
8				Seasonal Saturate
10				
12				
14				

Soil Map Unit - TrB

Slope - 4%

Landscape Position - Footslope

Landscape Type - Concave

### 3.4 References

1. Small Scale Waste Management Project, University of Wisconsin, Madison. Management of Small Waste Flows. EPA 600/2-78-173, NTIS Report No. PB 286 560, September 1978. 804 pp.
2. Tyler, E. J., R. Laak, E. McCoy, and S. S. Sandhu. The Soil as a Treatment System. In: Proceedings of the Second National Home Sewage Treatment Symposium, Chicago, Illinois, December 1977. American Society of Agricultural Engineers, St. Joseph, Michigan, 1978. pp. 22-37.
3. Hillel, D. I. Soil and Water: Physical Principles and Processes. Academic Press, New York, 1971. 302 pp.
4. Flach, K. W. Land Resources. In: Recycling Municipal Sludges and Effluents on Land. Champaign, University of Illinois, July 1973.
5. Bennett, E. R., and K. D. Linstedt. Sewage Disposal by Evaporation-Transpiration. EPA 600/2-78-163, NTIS Report No. PB 288 588, September 1978. 196 pp.
6. Pickett, E. M. Evapotranspiration and Individual Lagoons. In: Proceedings of Northwest Onsite Wastewater Disposal Short Course, University of Washington, Seattle, December 1976. pp. 108-118.
7. Pruitt, W. O. Empirical Method for Estimating Evapotranspiration Using Primarily Evaporation Pans. In: Evapotranspiration and Its Role in Water Resources Management; Conference Proceedings, American Society of Agricultural Engineers, St. Joseph, Michigan, 1966. pp. 57-61.
8. Beck, A. F. Evapotranspiration Pond Design. Environ. Eng. Div., Am. Soc. Civil Eng., 105 411-415, 1979.
9. Bernhart, A. P. Treatment and Disposal of Wastewater From Homes by Soil Infiltration and Evapotranspiration. 2nd ed. University of Toronto Press, Toronto, Canada, 1973.
10. Soil Conservation Service. Soil Survey Manual. USDA Handbook 18, U.S. Government Printing Office, Washington, D.C., 1951. 503 pp.
11. Studies on Household Sewage Disposal Systems. Environmental Health Center, Cincinnati, Ohio, 1949-3 pts.
12. Bouma, J. Evaluation of the Field Percolation Test and an Alternative Procedure to Test Soil Potential for Disposal of Septic Tank Effluent. Soil Sci. Soc. Amer. Proc. 35:871-875, 1971.

13. Winneberger, J. T. Correlation of Three Techniques for Determining Soil Permeability. *Environ. Health*, 37:108-118, 1974.
14. Healy, K. A., and R. Laak. Factors Affecting the Percolation Test. *J. Water Pollut. Control Fed.*, 45:1508-1516, 1973.
15. Bouma, J. Unsaturated Flow During Soil Treatment of Septic Tank Effluent. *J. Environ. Eng., Am. Soc. Civil Eng.*, 101:967-983, 1975.
16. Onsite Wastewater Management. National Environmental Health Association, Denver, Colorado, 1979.
17. Machmeier, R. E. How to Run a Percolation Test. Extension Folder 261, University of Minnesota, St. Paul, 1977.
18. Penman, H. L. Estimating Evaporation. *Trans. Amer. Geophys. Union*, 37:43-46, 1956.